

FASTFOOT® INSTALLATION

FASTFOOT® WIDTHS

Manufactured in three widths, on 100' long rolls:

- FF50 - Narrow, 50", footings up to 18" wide, 11" deep
- FF62 - Standard, 62" width, up to 24" wide, 14" deep
- FF74 - Wide, 74" width, up to 36" wide, 14" deep

Fabric Width Rule = footing width + twice height + 10"

For deeper footings, use wider fabric. Where footing is too large for FF74, edge form each side of the footing and nail overlapping edges to ground (see page 2).

Note: if 'fabric height' is greater than 15", install a second 2x4 to reduce the bulge and fabric tension.

1 SETUP SCREED BOARDS

Layout the outside footing stakes (steel or 1x4s) around the perimeter using a string line.

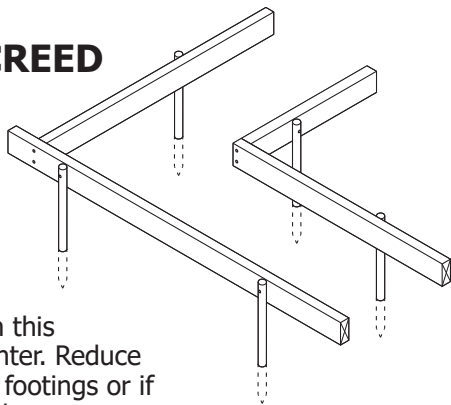

Drive the stakes on this line about 6' on center. Reduce spacing for deeper footings or if the ground is less dense.

Drive inside stakes opposite each outside stake using a 1x2 cut to footing width. Top of footing is 3" less than the footing contact width (see diagram above right).

SOLIDLY ATTACH SCREED BOARDS

With fabric, lateral forces are reduced by 75%, but downward tension is increased accordingly. Use 2 angled nails or 1 screw per stake.

2 STAPLING FASTFOOT®

Fastfoot® easily adjusts to different footing depths. Determine the correct location of the fabric edge on the screedboard by:

- Place one hand on correct 'Fastfoot width line' on ground and bring fabric edge snugly over the screed board. Hammer tack Fastfoot 6" on center to the top of the screed board.
- Note the location of a colored 'edge line' with respect to the screed board under the fabric. Use this 'edge line' to position the fabric for stapling AS LONG AS the footing depth stays the same.
- If the footing depth increases, let the fabric OUT by placing hand on the same 'width line' and note the new edge line over the screed board.

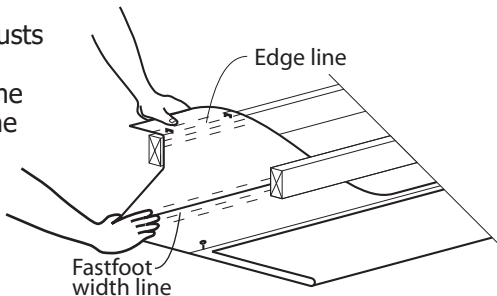

TOOLS & SUPPLIES

Sharp scissors, hammer tacker with 3/8" staples, 2" sheathing tape, hammer, skill saw, stake nails or screws, stakes, 2x4s, 3/4" plywood for steps, 1x4s for cleats, laser for setting height on stakes.

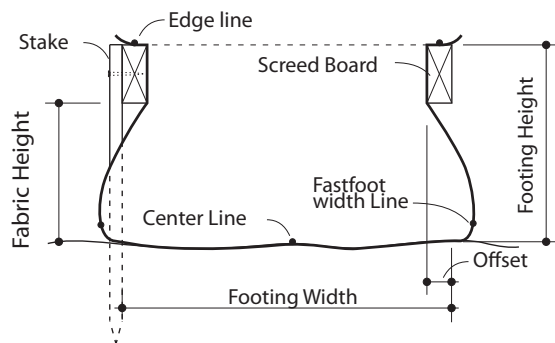

3 INSTALL CORNERS

Using the edge line determined in step 2, staple corner edges to top of screed boards at 12" on center, using a hammer tacker with 3/8" staples.

If sewn corners are not available, run fabric 16" past corner, cut and staple in position. Use scissors to trim on inside of corner. Continue in new direction. (Visit website for details on folding corners.)

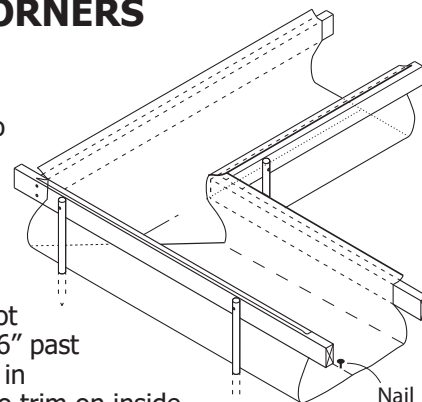

4 INSTALL STRAIGHTS

Hammer tack two edges of the Fastfoot® roll on top of the corner fabric with a 10" overlap. Unroll past next corner and cut with a 10" overlap. Hammer tack both edges 12" on center using the predetermined edge line.

Nail center line to prevent movement by wind and concrete. Use sheathing tape on overlaps and nail holes to prevent concrete escaping form and moisture entering footing. If the ground will not support nails, use bricks or stones.

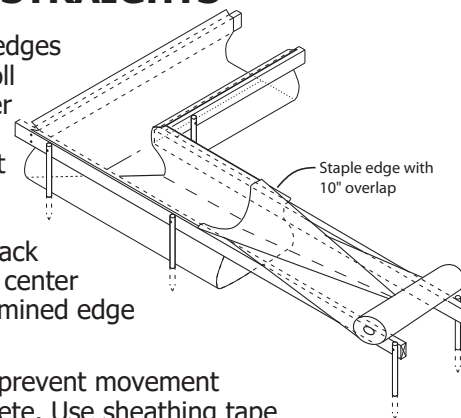

T-JUNCTIONS

Run fabric through junction. Cut an 'inverted T' in junction area with lower cut along footing width line. Fold and staple tabs. Run intersecting fabric into junction allowing a 10" overlap. Cut overlap along footing width line, and staple overlapping tabs to screed boards.

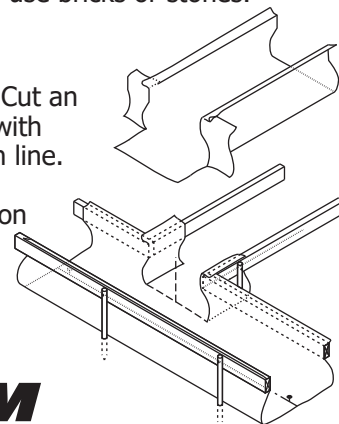

**FAB-FORM
INDUSTRIES LTD.**

www.fab-form.com

Toll free: (888) 303-FAST (3278)

**GreenSpec®
LISTED**

www.GreenSpec.com

DAMP PROOFING

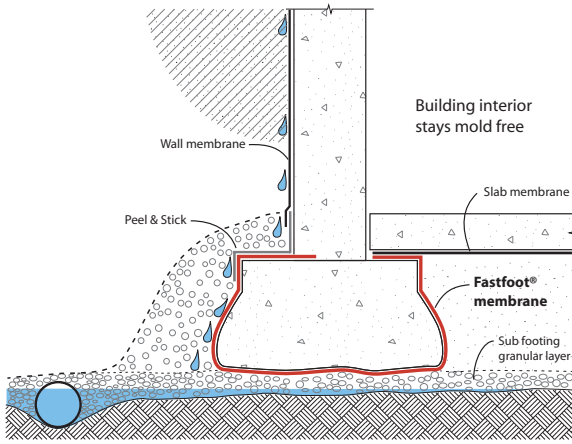

Leave screed boards & stakes in position. Pull Fastfoot® off screeds and tape two edges together on top of footing with 2" sheathing tape. Form and pour wall. After stripping (if required) run 12" width of peel & stick membrane along top of footing (covering staple holes in Fastfoot®) and up side of wall. Lap bottom edge of wall membrane over vertical peel & stick. On the inside, tape underslab membrane to interior Fastfoot®.

STEP INSTALLATION

Drive pairs of 2x4 stakes into the ground and screw to upper and lower screed boards. Trim upper screed boards flush with vertical stakes. Drive additional stakes if the distance between the stake and bank is greater than 15". Install lower level fabric.

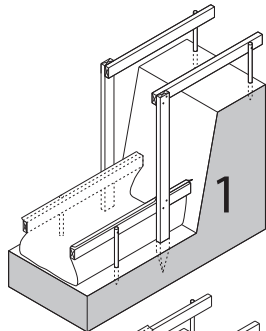

Run fabric up bank to form step. Most steps are too deep to form with a single fabric width. Either run two widths of fabric as edging or turn the fabric 90 degrees to obtain the required width.

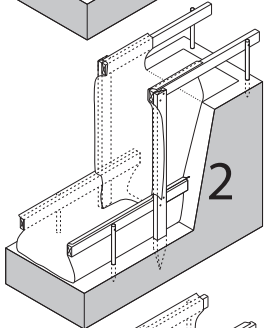

Install the upper level fabric with an 10" overlap. Cut the overlap on the footing width line, letting center portion hang down bank.

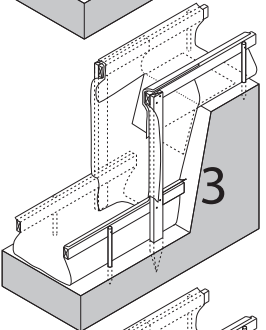

Screw plywood bulkhead in position and brace as required.

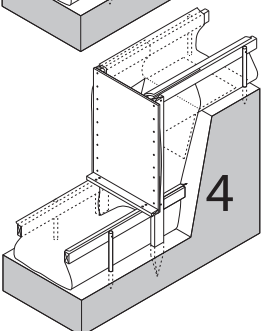

Step fabric can also be installed without cutting, see website for installation details.

EDGING INSTALLATION

1 SETUP SCREED BOARDS

Drive stakes around the perimeter of the proposed slab or footing at about 5' on center.

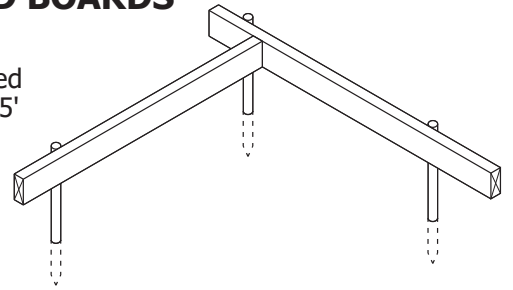

SOLIDLY ATTACH SCREED BOARDS

Concrete produces downward tension in fabric. Use 3 nails or 2 screws (2-1/4") per stake.

For slab edging use deeper edge lumber (2x6 or 2x8) if a flat face is required for exposed edge. For footings, drive stakes on the footing line, so the 1-1/2" will save concrete.

2 INSTALL FASTFOOT®

Staple the edge of the fabric to the top of the screed board using a hammer tacker with 3/8" staples on about 8" centers.

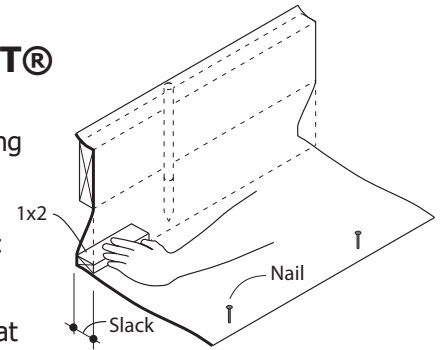

Provide some slack in the fabric by using a 1x2 as shown to prevent excessive downward pressure. Nail fabric to ground at 4' centers to stop fabric pull-out from concrete pressure. Allow an 10" overlap on all joints.

3 CORNERS

For outside corners, fold fabric on ground and nail through three layers to hold in position. For inside corner, cut fabric on the ground to enable it to go around corner and nail in position.

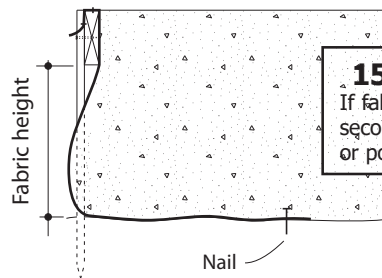
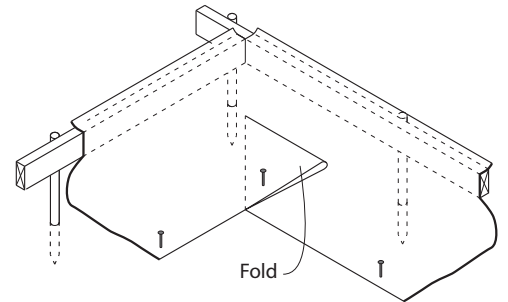

15" FABRIC HEIGHT RULE

If fabric height is greater than 15", install second 2x4 to reduce bulge and tension, or pour concrete in separate lifts.

EDGE SIZING CHART

Fabric width	Fabric name	Maximum Height
37"	Edging	16"
50"	Narrow	22"
62"	Standard	28"
74"	Wide	34"

Note: FF37 is obtained by chopping FF74 roll in half.



www.GreenSpec.com

FAB-FORM INDUSTRIES LTD.

www.fab-form.com

Toll free: (888) 303-FAST (3278)